

PRECISION METEOROLOGICAL THERMO-HYGROMETER MODEL MET-2010

BULLETIN MET-2010

$$p = \frac{\rho RT}{m}$$

$$S(\lambda) = S_0(\lambda) e^{-\alpha(\lambda)}$$

$$B(T) = bT^4$$

Description

The Model MET-2010 is a complete precision ambient temperature and dew/frost point measuring system designed for the meteorologist, climatologist, or atmospheric scientist. It provides a superior degree of accuracy and reliability, achieving an absolute accuracy of $\pm 0.05^\circ\text{C}$ in measuring ambient temperature over the entire $\pm 50^\circ\text{C}$ range. Dew point temperatures above 0°C are determined to an accuracy of $\pm 0.2^\circ\text{C}$, while frost point temperatures down to -70°C have an accuracy of $\pm 0.5^\circ\text{C}$. The system consists of an aspirated triple-shielded platinum resistance thermometer and an intelligent, chilled mirror dew/frost point hygrometer sensor. Above 0°C , the hygrometer tracks the dew point temperature; below 0°C , it tracks the frost point temperature.

Ambient temperature is highly variable in both time and space, and a single measurement reflects a limited space-time domain. Historically, techniques other than direct measurement of ambient temperature have provided support for the global warming issue, but precise knowledge of atmospheric ambient temperatures is a fundamental component to understanding the Earth's climatic mechanisms. As we continue collecting ambient temperature data for the climatological database, improvements in the basic measurement are required. While some of the problems of measuring ambient temperature cannot be easily eliminated, basic instrumental and observational errors in climatic temperature measurements can be reduced using the MET-2010.

Features

- Highest accuracy available on the market
- "Smart" sensor, microprocessor-managed
- Outputs in analog voltage and digital RS-232, inputs protected from polarity reversal and overvoltage
- Reliable solid-state detection technology; temperature depression permitting dew/frost point measurement to as low as 6% RH
- Specially plated hygrometer mirror to prevent corrosion and readily accessible for cleaning through a control box port. No need to open the control box to check the mirror, a plus for maintenance in inclement weather
- Automatic detection and indication of fan failure
- Precision platinum resistance thermometer
- Thermometer triple radiation shields



MET-2010 system

Applications

The MET-2010 offers nearly an order of magnitude more precision than existing ambient temperature measuring systems, making it ideally suited for:

- Professional grade meteorological stations
- Aviation weather system upgrades
- Field accuracy checks of other field sensors
- Industrial calibration laboratories
- Agricultural and global climate change research

Mechanical Configuration

The MET-2010 electronics are packaged in a weatherproof NEMA-type PVC enclosure. The thermometer radiation shields are manufactured of aluminum with an electrostatically-applied white powder coating for long life. Electrical and mechanical components are designed to operate over a temperature span of $\pm 50^\circ\text{C}$; reduced aspirator motor life can be expected when system installation temperatures are below -50°C due to bearing lubricant degradation. The system typically mounts two meters above the ground to a customer tower or support and aimed into the prevailing wind.

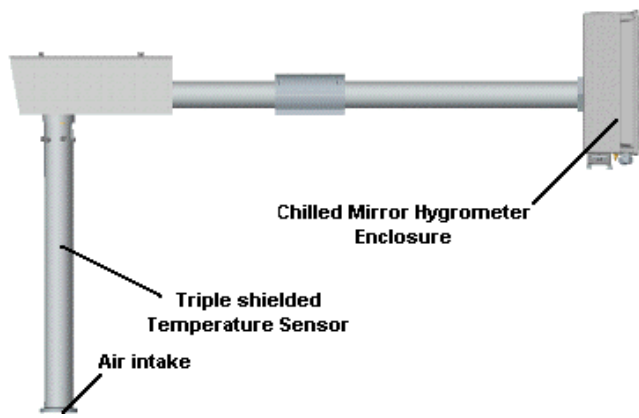

Side view of MET-2010.

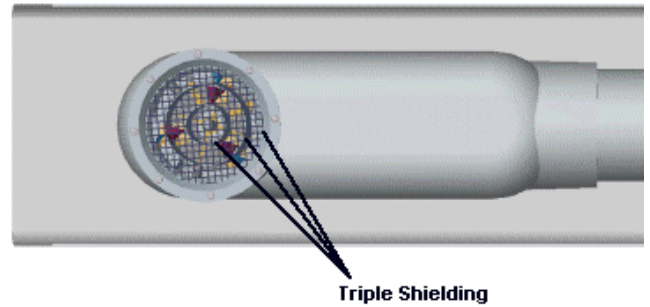

Detailed view of bottom of temperature sensor showing triple shielding, air intake, and screen.

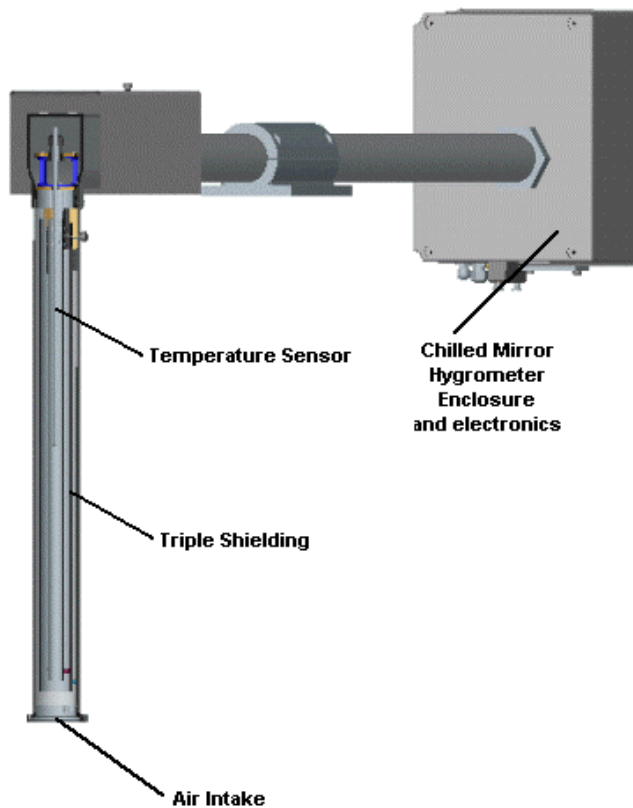

Cross section identifying temperature sensor, triple shielding, and air intake.

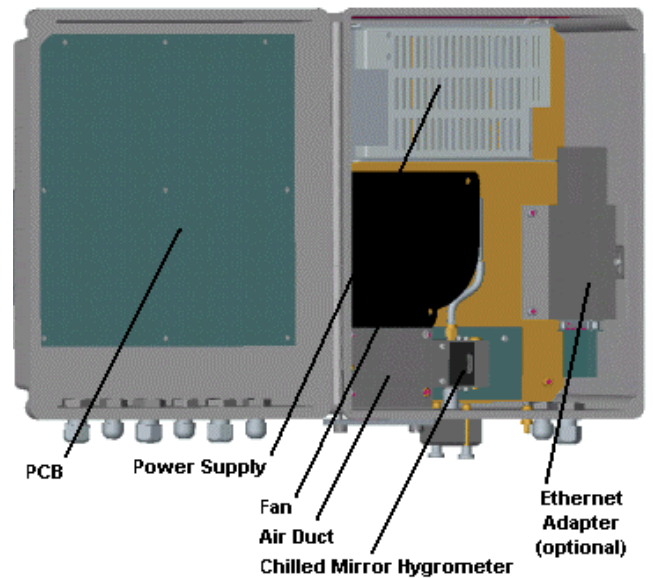

Chilled Mirror Hygrometer enclosure and instrument electronics.

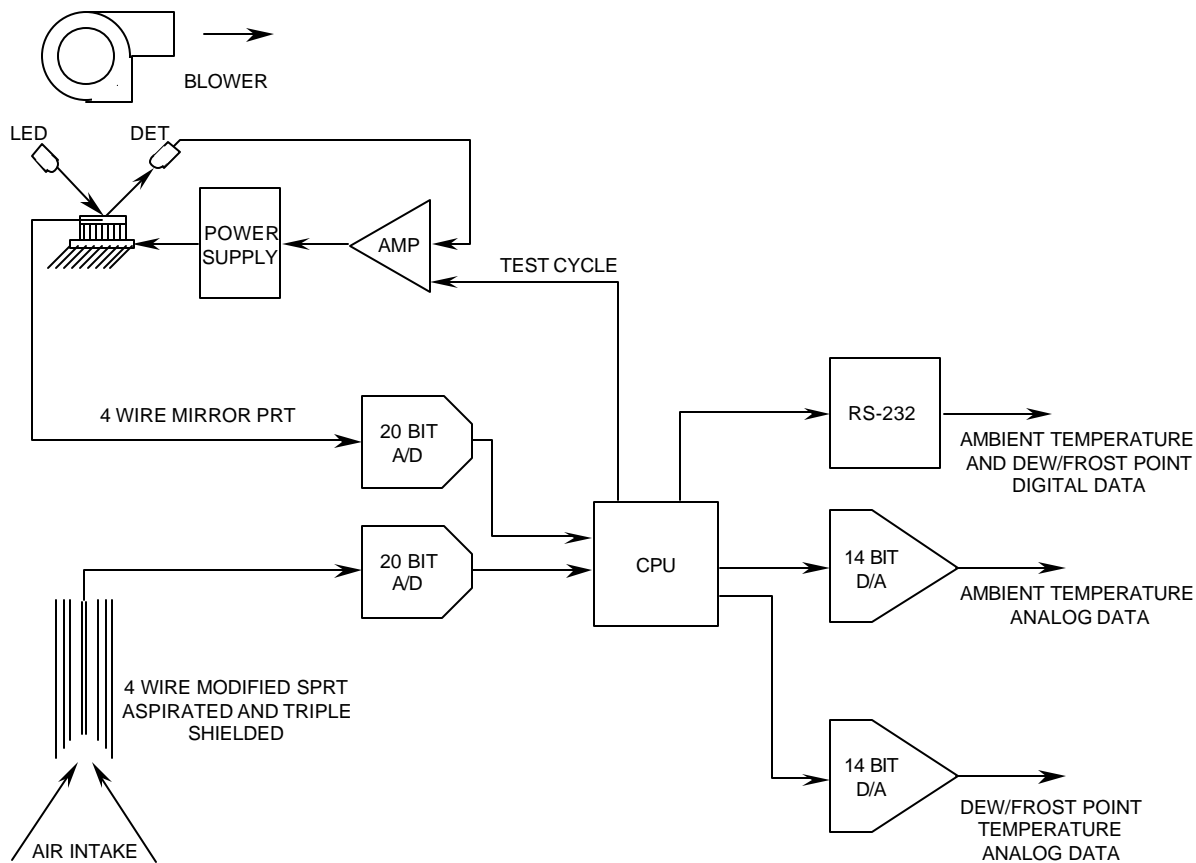

MET-2010 functional block diagram

Uncertainty Analysis

The ambient temperature measuring system employs a modification of the four-wire Standard Platinum Resistance Thermometer (SPRT) design. The modifications preserve the fundamental features of the SPRT, including minimum stem conduction error, strain-free mounting of the platinum element, and four-wire Kelvin readout. Features not required by the meteorological application are eliminated, bringing the SPRT within the range of affordability for field measurements. The MET-2010's 100 Ohm platinum resistance thermometer element is calibrated after packaging in a NIST-traceable temperature bath (Hart Scientific Model 7025 high precision bath). Alone, the thermometer provides an uncertainty of $\pm 0.028^{\circ}\text{C}$. The thermometer is then mounted in an aspirated, triple-walled aluminum radiation shield that has a worst case, full-sun, radiation error of less than $+0.005^{\circ}\text{C}$. Readout of the 100Ω PRT element is achieved through the use of a 20-bit analog-to-digital bridge completion circuit that excites the resistance element with a current of $400\ \mu\text{Aac}$. This results in a self-heating error of less than 0.0016°C and elimination of thermoelectric voltages.

Several potential sources of error should be considered in designing an ambient temperature measuring system that strives to offer absolute accuracy of $\pm 0.05^{\circ}\text{C}$ or better. The major contributors to the uncertainty analysis in a instrument of this type are the solar radiation shielding error, the thermometer stem conduction error, and the PRT self-heating error. The worst-case MET-2010 errors from these sources are $+0.005^{\circ}\text{C}$, $\pm 0.00003^{\circ}\text{C}$ and $+0.0016^{\circ}\text{C}$, respectively. A variety of other random RMS errors include the calibration limits of the thermometer bath ($\pm 0.028^{\circ}\text{C}$), reference resistor drift errors (± 0.00607), amplifier gain errors ($\pm 0.00729^{\circ}\text{C}$), and the linearity error ($\pm 0.0045^{\circ}\text{C}$). When combined, these errors produce a worst-case uncertainty of:

$$\begin{aligned}
 E &= E_{\text{rms}} + E_{\text{heating}} + E_{\text{sol}} \\
 &= 0.00973 + 0.0016 + 0.005 \\
 &= 0.016^{\circ}\text{C}
 \end{aligned}$$

Although the RMS uncertainty analysis for all components of the system is 0.016°C , the MET-2010 is conservatively rated at an accuracy of $\pm 0.05^{\circ}\text{C}$.

Digital Output Data Format

The RS-232 serial digital output is used to fully cover the resolution and precision of measurements. The output stream is similar to other automated surface observation system thermohygrometers (e.g. the TSL Model 1800). The MET-2010 responds to a "T" string at the serial port with a constant length record. This includes a T echo; then two, five-digit-long right-justified temperature and dew point values (selectable as °C or °F via an on-board jumper); followed by a mirror status and blower status; terminating with CR and LF characters. An example of a MET-2010 fixed length output record follows:

```
T -0.85 22.54 DIRTY=0 FANFAIL=0
```

Internal CPU Operation

The Met-2010 is controlled by an embedded microprocessor CPU that serves several functions:

- At power up, the processor monitors a heating cycle whereby the chilled mirror is heated to approximately 48°C and a measurement of the dry mirror reflected signal is obtained.
- Measurements are compared to a reference signal to determine if the mirror is in need of cleaning. A *test heating cycle* is automatically performed once daily at midnight UTC, as determined by an on-board clock/calendar.
- While monitoring the serial port for commands, continuous measurements of the dew point and ambient temperature are made by the ADC.
- Upon receipt of the query command (T1), the CPU outputs a single data record, containing the dew point temperature, ambient temperature, and mirror condition of "CLEAN" or "DIRTY".
- The CPU performs digital filtering of the data to minimize measurement noise. It performs a quadratic fit to within $\pm 0.001^\circ\text{C}$ of ITS-90 for converting the SPRT resistance values to degrees centigrade.
- The D/A converter's analog output indicates the prevailing dew point and ambient temperatures.

Electrical Connections

Two foil-shielded 10' (3m) long cables are supplied with pig tails for interface to the user's junction box:

- DC power input; isolated return analog output
- RS-232 three-wire digital interface (hardware handshaking lines are not required)

Cable runs are possible up to 50' via a user cable splice or junction box. Both DCE and DTE RS-232 serial interfaces can be interfaced.

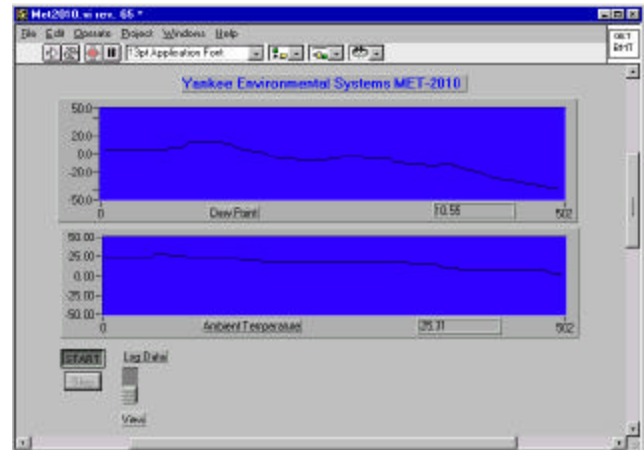

MET-2010 software interface

Available Options

- Spare aspiration blower
- MS-Windows 9x/NT or Mac viewing software
- Temperature-only version (PMT-2005)
- RJ-45 interface via 10BaseT to a LAN

Development History

The MET-2010 was the result of an intensive five-year R&D effort, sponsored in part by the United States Department of Agriculture, to develop and field test an improved means of measuring ambient temperature at climatological monitoring sites. It represents the first major improvement in air temperature measurement since the introduction in the 1970s of the Gill radiation shield.

The measurement of ambient air temperature is fundamental to the study of global climate and climate change mechanisms. Assessing the degree of global warming occurring from the increase of so-called "greenhouse gases" has been frustrated by variations in long-term temperature records due to earlier ambient temperature sensors that had calibration drifts. These variations stemmed from a variety of factors, including changes in the technology of measurement, methods of exposing the instrument, frequency of data collection, methods of calibration, and the training and dedication of the person collecting the data.



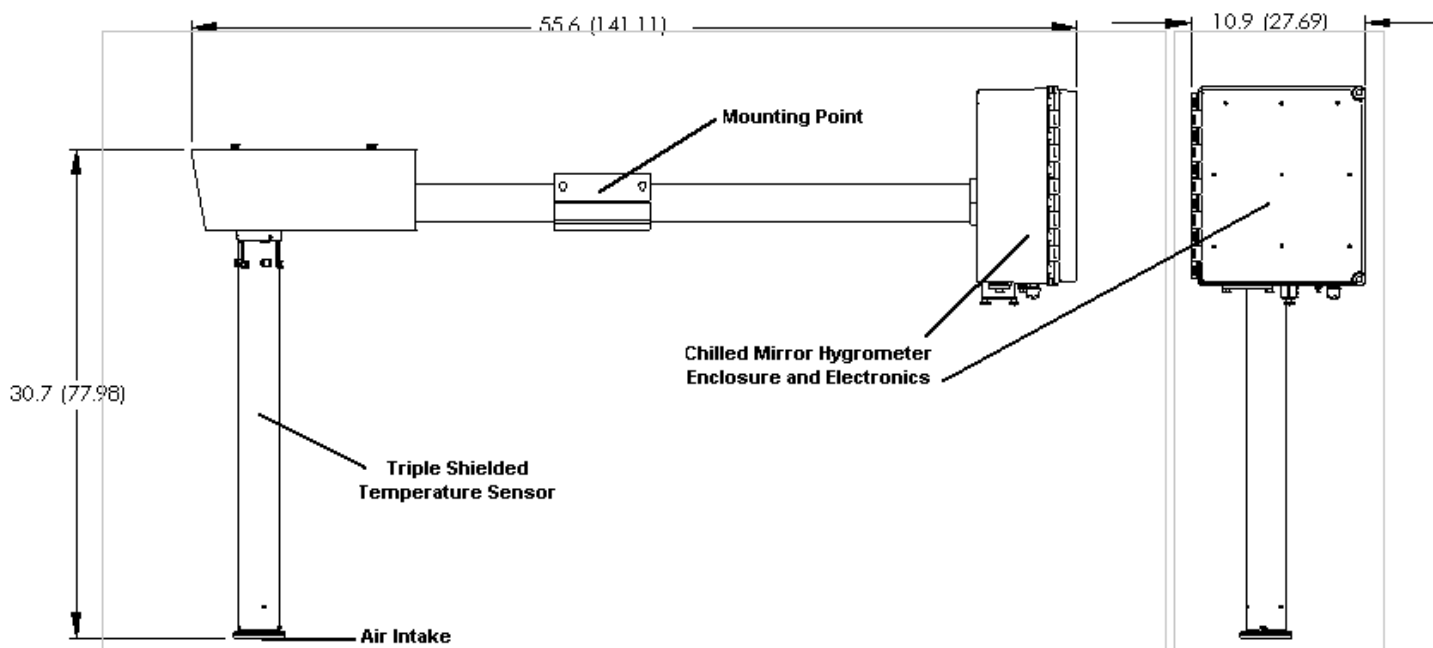

Mechanical Interface, Dimensions in inches (cm)

Specifications

Power Required	11-14 Vdc, 4 Adc max, 1.3A nominal; input to system protected from polarity reversal, surges, & overvoltage	Environmental operating temperature range	±50°C
----------------	---	---	-------

AMBIENT TEMPERATURE MEASUREMENT:

Ambient temperature measuring range	±50°C
Ambient temperature accuracy	±0.05°C
Analog output	±5.000 Vdc corresponding to ±50.0°C, (14-bit DAC yields >0.01°C resolution)
Digital output	RS-232, 9600 baud 8-N-1, ASCII (14-bit 0.01°C resolution)
Air flow	Approximately 400 FPM

DEW POINT MEASUREMENT:

Dew/frost point range	At 22°C, ambient temperature dew/frost measurements can be made to -18 °C.
Dew/Frost Point Accuracy	Dew points: ±0.2 °C; Frost Points: ±0.5°C
Sensitivity	±0.01 °C
Repeatability	±0.01 °C
Hysteresis	None
Slew rate	Typically 1.5 °C per second



YANKEE ENVIRONMENTAL SYSTEMS, INC.
 Airport Industrial Park
 101 Industrial Blvd., Turners Falls, MA 01376 USA
 Tel: (413) 863-0200 Fax: (413) 863-0255
 E-mail: info@yesinc.com http://www.yesinc.com