

AUTOMATIC TOTAL SKY IMAGER MODEL TSI-880

BULLETIN TSI-880



Model TSI-880 Automated Total Sky Imager

Principle of Operation

Images from the sky are captured via a solid-state CCD imager looking downward onto a heated, rotating hemispherical mirror. A shadowband on the mirror blocks the intense direct-normal light from the sun, thereby protecting the imager optics. An embedded image-processing algorithm captures and displays the images. Results are presented in real time via a web server, both statically and via *panoramic views* and *animations*.

The TSI-880 is a daytime imager. Once the sun rises above a user-selectable minimum solar zenith angle, image acquisition begins. The analysis step first masks out obstructions—the imager, its arm, and the sun-blocking band. Fractional cloud cover is determined by a sophisticated embedded algorithm. The system can be configured to operate either standalone or networked. In standalone mode, it can be interfaced directly to existing surface weather systems via its RS-232 serial interface. Or it can be networked to the Internet via its 10/100-BaseT or telephone modem (PPP) interfaces. Networked, users can view real-time processed images locally or remotely via a web browser.



$$p = \frac{\rho RT}{m}$$

$$S(\lambda) = S_0(\lambda) e^{-m \cdot \delta(\lambda)}$$

$$B(T) = bT^4$$

General Description

The Total Sky Imager Model TSI-880 is an automatic, full-color sky imager system that provides real-time processing and display of daytime sky conditions. At many sites, the accurate determination of sky conditions is a highly desirable yet rarely attainable goal. Traditionally, human observers reported sky conditions, resulting in considerable discrepancies from subjective observations. In practice, the use of human observers is not always feasible due to budgetary constraints. The TSI-880 now replaces the need for these human observers under all weather conditions. An onboard processor computes both fractional cloud cover and sunshine duration, storing the results and presenting data to users via an easy-to-use web browser interface. The self-contained design makes it well suited for mission-critical applications such as aviation and military meteorology monitoring. It captures images into standard JPEG files that are analyzed into fractional cloud cover; if networked via TCP/IP (10/100BaseT) or PPP (modem) it becomes a *sky image server* to remote any user via the web.

Features

- Embedded processor; no external workstation is required to operate system
- Open architecture uses JPEG file format and TCP/IP protocols; real-time data via the Internet permits remote monitoring
- Web browser-based interface supports MS-Windows, Macintosh, and UNIX users
- Reliable solid-state CCD technology with heavy duty removable imager assembly
- Readily interfaced to existing weather data collection systems via RS-232 or TCP/IP
- Environmentally sealed for long life
- Optional Data Storage Module permits remote operation and rapid data retrieval

Applications

- Cloud cover and present weather conditions
- General aviation meteorology
- Military border and air space monitoring
- Remote sensing and atmospheric research
- UV-B, pollution, and research

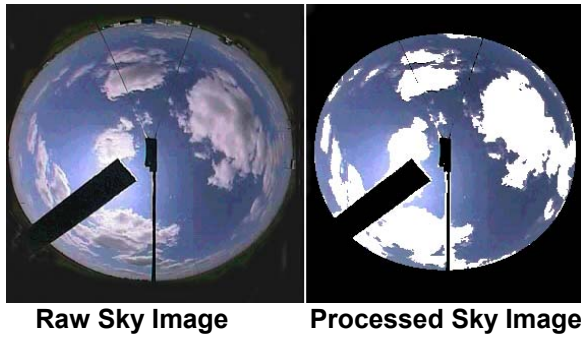

Side-by-side cloud images show a raw sky image before any processing, and the same image after a software filter is applied. The filter algorithm clearly defines the clouds so that fractional cloud cover can be readily calculated. TSI-880 users can fine-tune the algorithm in real time to meet special local requirements or adapt to local weather characteristics.

Software Architecture

The TSI-880 uses a sophisticated server-based embedded processing architecture that can support multiple networked systems via the Internet. Because the TSI-880 contains its own onboard image processor, users only need a web browser to adjust the cloud cover extraction algorithms remotely, without any need for special software and without taxing the display workstation. Images can be displayed as panoramic views using the optional Data Visualization Engine (DVE); images are stored as JPEG files in YESDAQ for later for later archival or reprocessing.

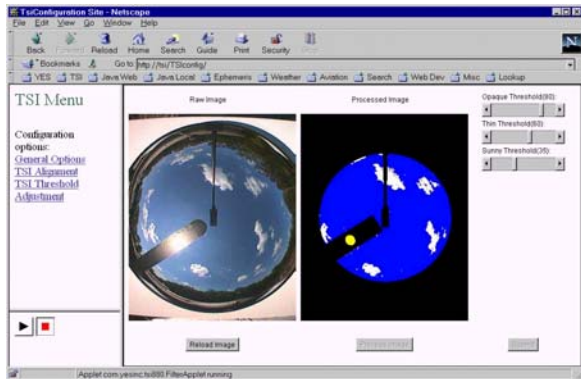

Real Time Display With Adjustment Control

Installation

System setup can be performed quickly: connect AC power and its ground wire to a ground rod, aim the system geographically north, and bolt it down to a stable, level surface (such as a table or concrete paver) via four 1/4-20 fasteners. Next, using a terminal emulator such as HyperTerm,

connect a PC's serial port to the system's console port and follow user prompts that walk you through assigning a unique TCP/IP address. Next, connect a networked PC to the system's Ethernet port. Point your web browser to the system's URL to set the system time, site latitude, and longitude. (Note: these steps can be performed prior to arriving at the site). Finally, check that the imager is properly aligned to the center of the mirror via the web-based alignment step shown below. The system now runs automatically.

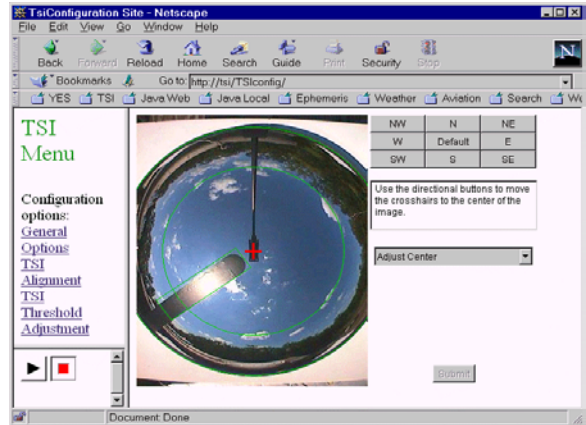

TSI-880 imager alignment check setup

Data Storage and Display Options

For remote sites that are not practical to connect directly to a telephone line or the Internet, the optional DSM-420 provides 420 MB of non-volatile, removable local storage. It permits operators to periodically retrieve data from remote sites and play it back on PCs or workstations. Typical image size is about 30 KB; the rate at which storage is used up depends on the capture interval and the current number of daylight minutes. For example, worst case, with 30 second samples and 16 hour days, the system will save about 29 MB of images a day.

The optional Data Visualization Engine with its YESDAQ database permits reprocessing of stored TSI-880 data as well as real-time playback and display of animations to one or more workstations via the web. (See the YESDAQ data sheet for more information).



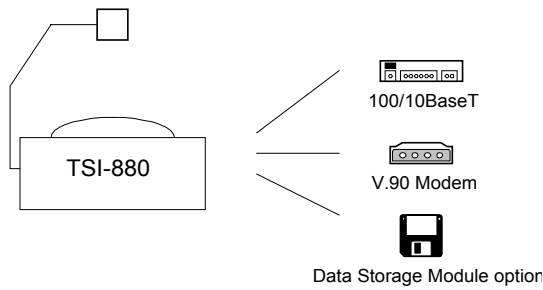

A TSI-880 can be directly connected to a LAN or telephone line to support real-time display, storage and backup to remote hosts. To support a wide variety of configurations it is equipped with these interfaces:

- 10/100BaseT Ethernet port for LAN links
- V.90 modem for PPP telephone links
- Data Storage Module option slot for remote retrieval of up to 440 Mb of data

Communication Link Methods

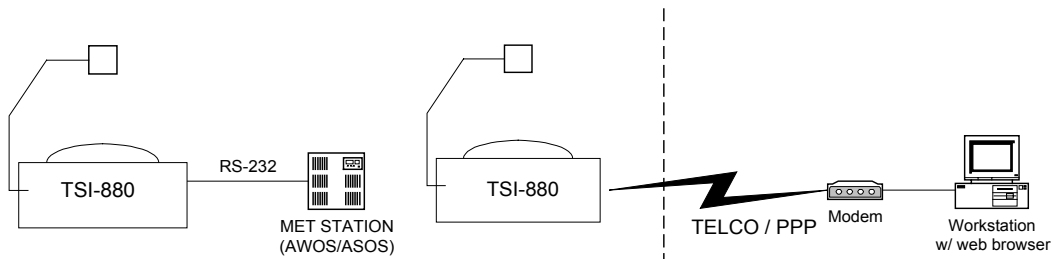

1. Remote Real Time Display via PPP dial up or direct RS-232 serial link to weather station

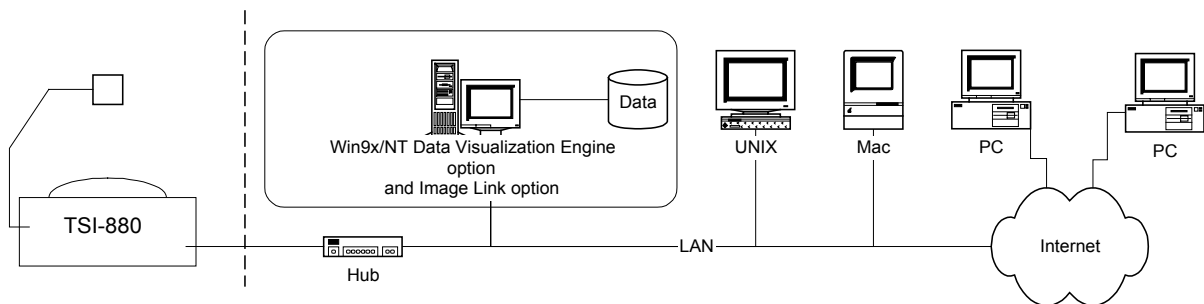

2. Local Real Time Display via LAN / Internet, shown with Data Visualization Engine option

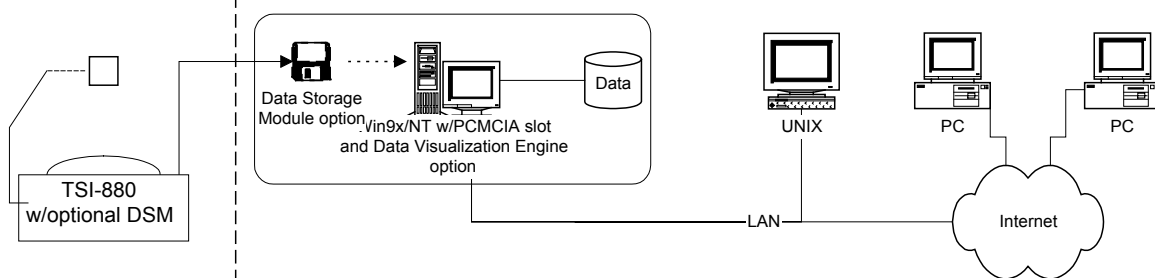

3. Remote archive display via Data Storage Module and Data Visualization Engine options

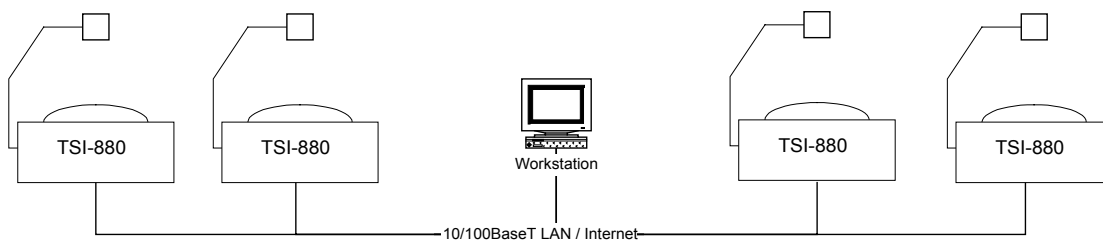

4. "One-to-Many" real time monitoring of multiple geographical areas from a central location

Mechanical Interface

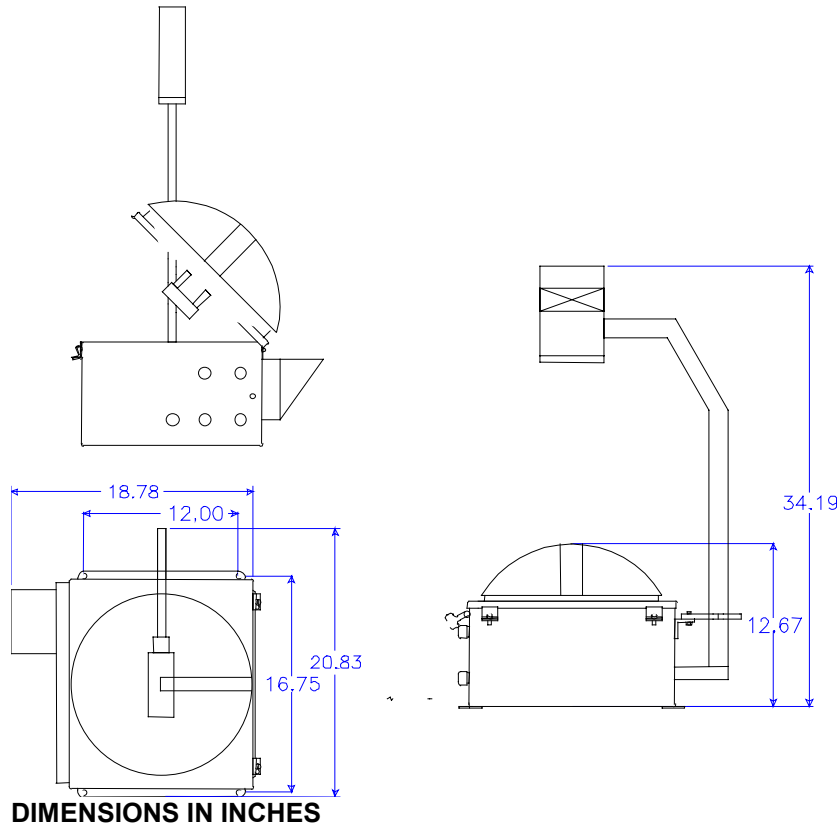

Specifications

Image Resolution:	352 x 288 color, 24-bit JPEG format
Sampling rate:	Variable, with max of 30 sec
Operating Temperature:	-40°C to +44°C
Weight/Size:	Approx. 70 lbs. (32 kg); dims: 20.83"x18.78"; height is 34.19"; mounts on 16.75x12" 1/4-20 bolt square
Power Requirements:	115/230 Vac; mirror heater duty cycle varies with air temperature: 560W with heater on / 60W off
Software:	None required for immediate real time display; uses Internet Explorer or Netscape Browsers on MS-Windows, Mac, UNIX (an optional DVE/YESDAQ package is available for data archiving, display, MPEG day movie creation and data reprocessing)
Data Telemetry:	LAN Ethernet (TCP/IP), telephone modem (PPP) or Data Storage Module option (for off grid sites)



YANKEE ENVIRONMENTAL SYSTEMS, INC.
 Airport Industrial Park
 101 Industrial Blvd., Turners Falls, MA 01376 USA
 Tel: (413) 863-0200 Fax: (413) 863-0255
 E-mail: info@yesinc.com <http://www.yesinc.com>